

PARTS LIST					
ITEM	QTY	PART NO.	PART DESCRIPTION	UNIT WT.	NET WT.
1	1	FACE-ASY1-30132	SINGLE SECTOR FACE MOUNT KIT W/ W/ 2-7/8" X 132" PIPES	700.64	700.64
2	1	FACE-PM496	FACE ASSEMBLY PIPE MOUNT KIT	145.77	145.77
TOTAL WT. #				846.41	

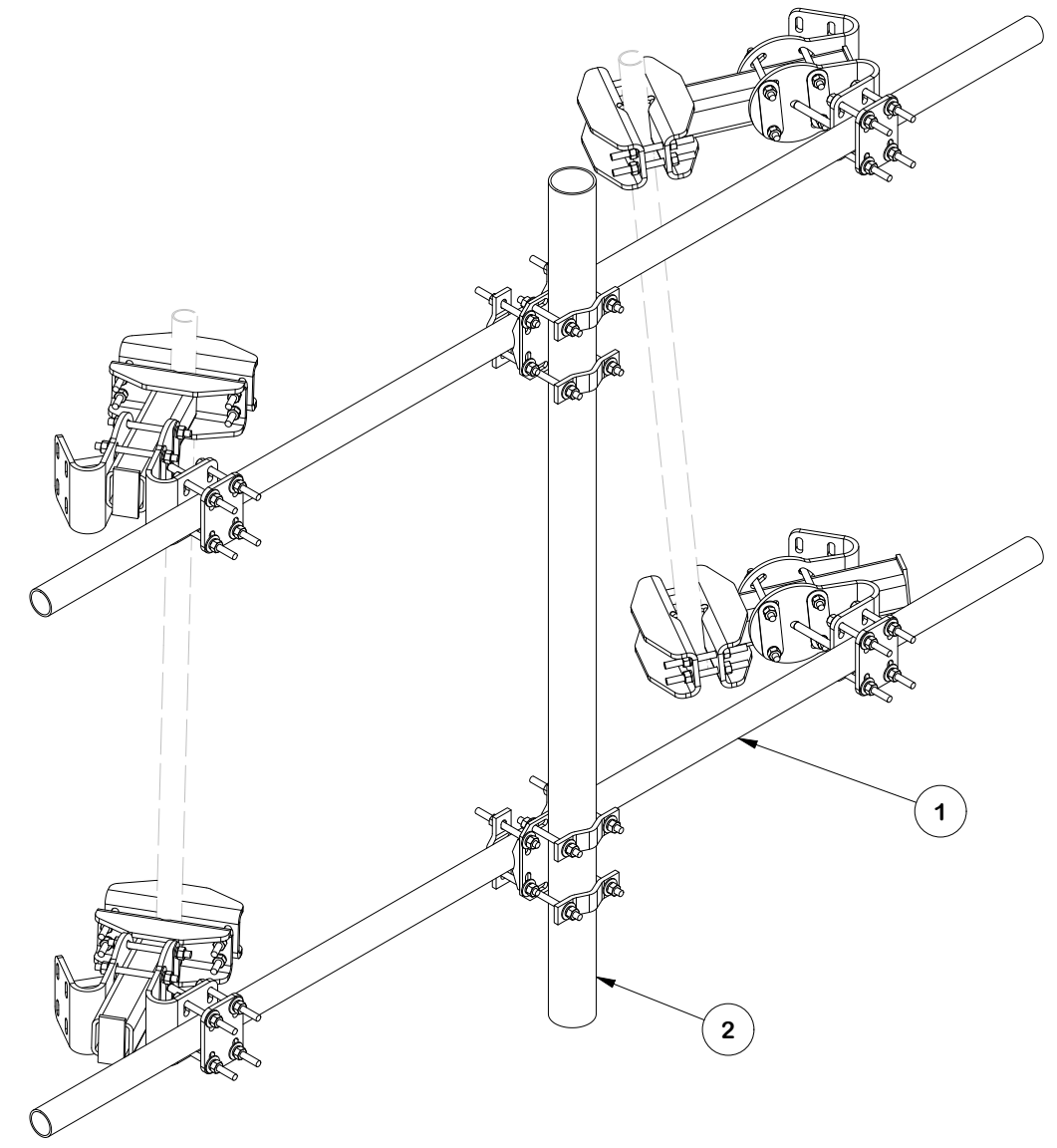
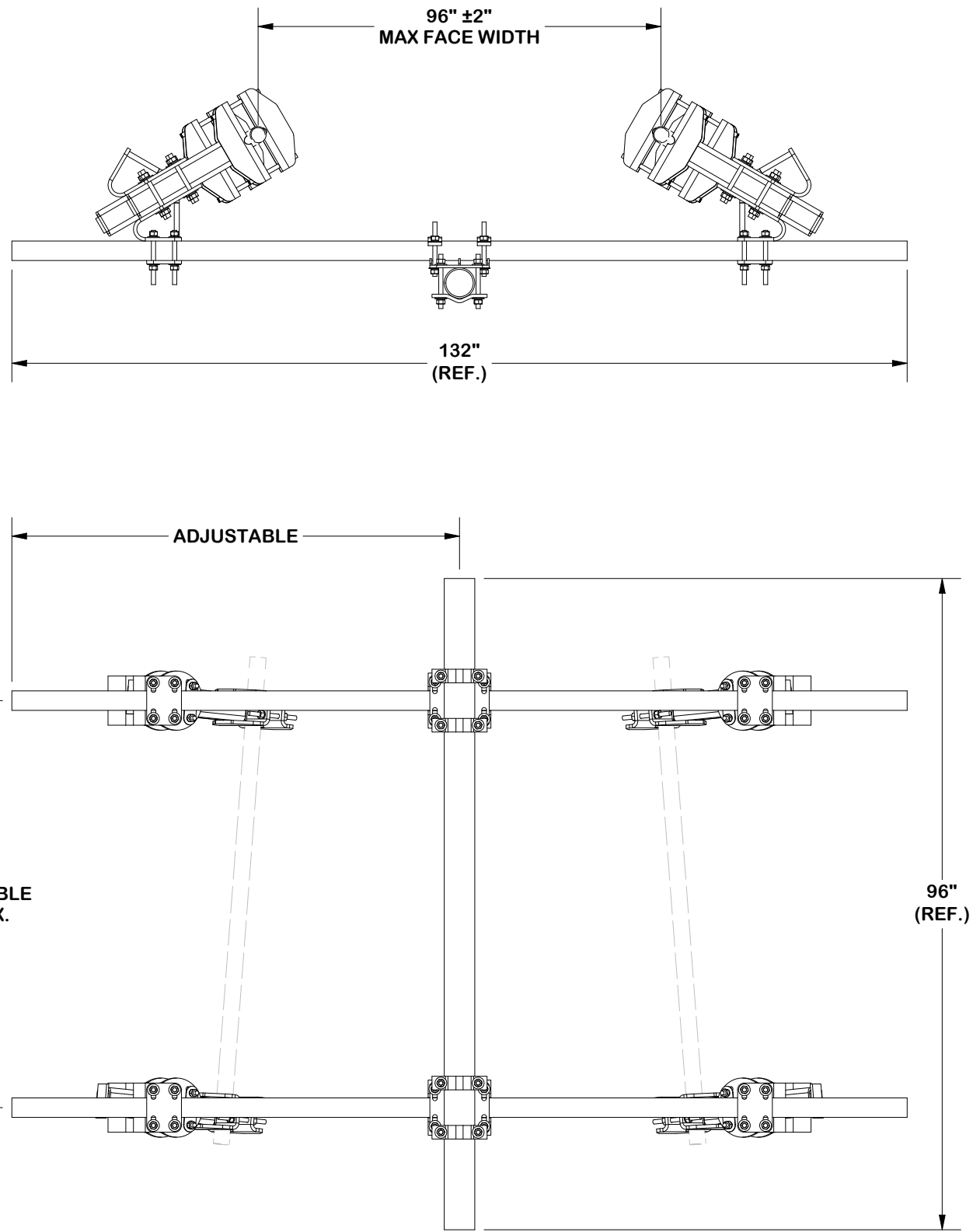

FINISH:  
HOT DIP GALVANIZED.

**TOLERANCE NOTES**

TOLERANCES ON DIMENSIONS, UNLESS OTHERWISE NOTED ARE:  
 SAWED, SHEARED AND GAS CUT EDGES ( $\pm 0.030"$ )  
 DRILLED AND GAS CUT HOLES ( $\pm 0.030"$ ) - NO CONING OF HOLES  
 LASER CUT EDGES AND HOLES ( $\pm 0.010"$ ) - NO CONING OF HOLES  
 BENDS AND ANGLES ARE  $\pm 1/2$  DEGREE  
 ALL OTHER MACHINING ( $\pm 0.030"$ )  
 ALL OTHER ASSEMBLY ( $\pm 0.060"$ )

PATENT INFORMATION: WWW.SITEPRO1.COM/PATENTS

PROPRIETARY NOTE:  
 THE DATA AND TECHNIQUES CONTAINED IN THIS DRAWING ARE PROPRIETARY INFORMATION OF VALMONT INDUSTRIES AND CONSIDERED A TRADE SECRET. ANY USE OR DISCLOSURE WITHOUT THE CONSENT OF VALMONT INDUSTRIES IS STRICTLY PROHIBITED.

DESCRIPTION  
**SINGLE-SECTOR MICROWAVE KIT  
 W/ 2-7/8" DIA. X 132" HORIZONTALS  
 AND PIPE MOUNT**

CPD NO. <b>SP1</b>	DRAWN BY <b>SDR 2/18/2026</b>	ENG. APPROVAL <b>JET 3/2/2026</b>
CLASS <b>87</b>	SUB <b>02</b>	DRAWING USAGE <b>CUSTOMER</b>
CHECKED BY <b>CSL 3/2/2026</b>		

**SITE PRO 1**  
 A valmont COMPANY

Engineering Support Team:  
 sp1engineering@valmont.com

PART NO. <b>FMW10-30</b>	DWG. NO. <b>FMW10-30</b>

**NOTES:**

1. THE MAXIMUM TAPER ADJUSTMENT IS 8° BASED UPON 60" SPACING OF ADJUSTABLE MOUNTING BRACKETS.
2. MAX. FACE WIDTH 96" ±2".

PARTS LIST							
ITEM	QTY	PART NO.	BOX NO.	PART DESCRIPTION	LENGTH	UNIT WT.	NET WT.
1	8	FACE-CCHALF	P-FACE-CCHALF	FACE ASSEMBLY CORNER CONNECTION (HALF)		33.15	265.20
2	4	FACE-LC	P-FACE-LC	FACE ASSEMBLY LEG CONNECTION		26.99	107.96
3	4	X-FACE-TW		TUBE WELDMENT		48.02	192.07
4	2	P30132		2-7/8" X 132" (2-1/2" SCH. 40) GALVANIZED PIPE	132.000 in	67.70	135.41
						<b>TOTAL WT. #</b>	<b>700.64</b>

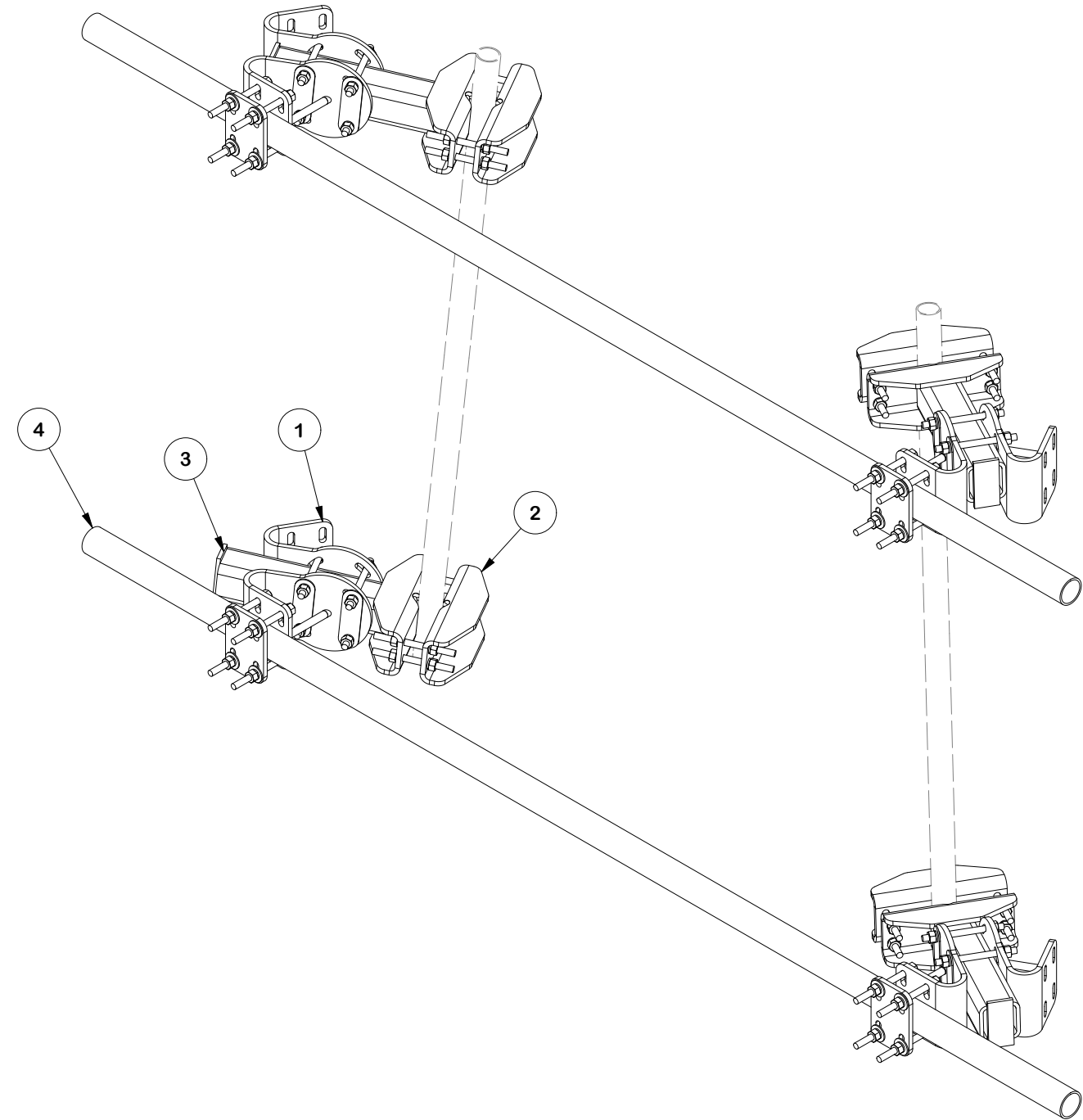
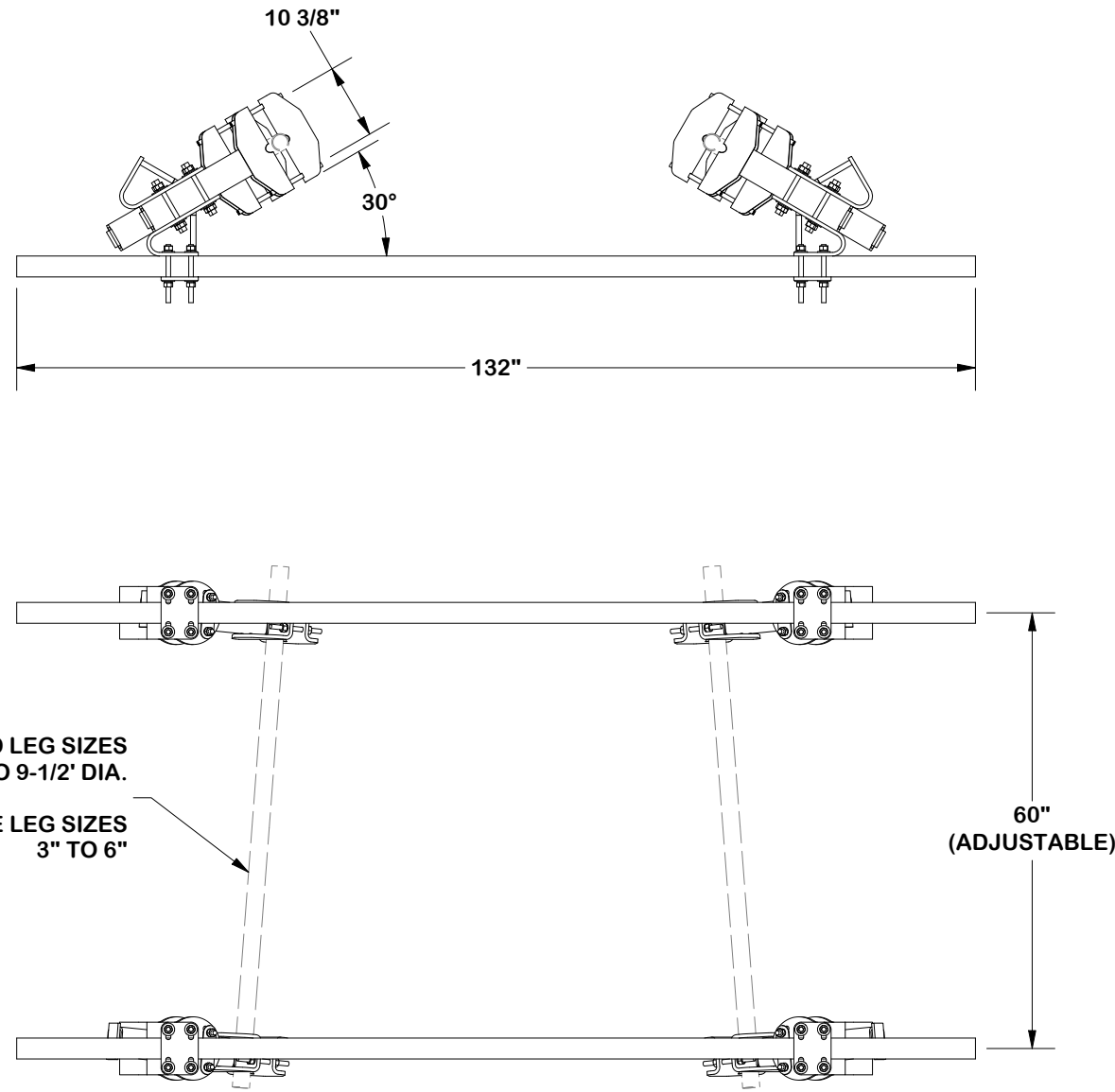

**FINISH:**  
HOT DIP GALVANIZED.

**TOLERANCE NOTES**

TOLERANCES ON DIMENSIONS, UNLESS OTHERWISE NOTED ARE:  
 SAWED, SHEARED AND GAS CUT EDGES ( $\pm 0.030"$ )  
 DRILLED AND GAS CUT HOLES ( $\pm 0.030"$ ) - NO CONING OF HOLES  
 LASER CUT EDGES AND HOLES ( $\pm 0.010"$ ) - NO CONING OF HOLES  
 BENDS AND ANGLES ARE  $\pm 1/2$  DEGREE  
 ALL OTHER MACHINING ( $\pm 0.030"$ )  
 ALL OTHER ASSEMBLY ( $\pm 0.060"$ )

PROPRIETARY NOTE:  
 THE DATA AND TECHNIQUES CONTAINED IN THIS DRAWING ARE PROPRIETARY INFORMATION OF VALMONT INDUSTRIES AND CONSIDERED A TRADE SECRET. ANY USE OR DISCLOSURE WITHOUT THE CONSENT OF VALMONT INDUSTRIES IS STRICTLY PROHIBITED.

DESCRIPTION  
**SINGLE-SECTOR MICROWAVE KIT  
 W/ 2-7/8" DIA. X 132" HORIZONTALS  
 AND PIPE MOUNT**



Engineering Support Team:  
 sp1engineering@valmont.com

REV	DESCRIPTION OF REVISIONS	CPD	BY	DATE
B	REVISED DRAWING TO SINGLE ASSEMBLY	SP1	ADB	11/18/2025
A	ADDED VIEWS FOR CLARITY	SP1	ADB	9/16/2025
<b>REVISION HISTORY</b>				

PATENT INFORMATION: WWW.SITEPRO1.COM/PATENTS

CPD NO.	DRAWN BY	ENG. APPROVAL
SP1	SDR 2/18/2026	JET 3/2/2026
CLASS	SUB	DRAWING USAGE
87	02	CUSTOMER
		CHECKED BY
		CSL 3/2/2026

PART NO.	DWG. NO.
FACE-ASY1-30132	FMW10-30

PARTS LIST						
ITEM	QTY	PART NO.	PART DESCRIPTION	LENGTH	UNIT WT.	NET WT.
1	1	X-FACE-TA	TAPER ADJUSTMENT WELDMENT		20.84	20.84
2	1	X-FACE-CP	CONNECTION PLATE	12 in	4.80	4.80
3	2	X-FACE-SB	SPACER BRACKET (WASHER)	6 3/4 in	0.45	0.90
4	6	G58R-8	5/8" x 8" THREADED ROD (HDG.)		0.70	4.18
5	8	G58FW	5/8" HDG USS FLATWASHER	1/8 in	0.07	0.56
6	12	G58LW	5/8" HDG LOCKWASHER		0.03	0.31
7	12	G58NUT	5/8" HDG HEAVY 2H HEX NUT		0.13	1.56
					TOTAL WT. #	33.15

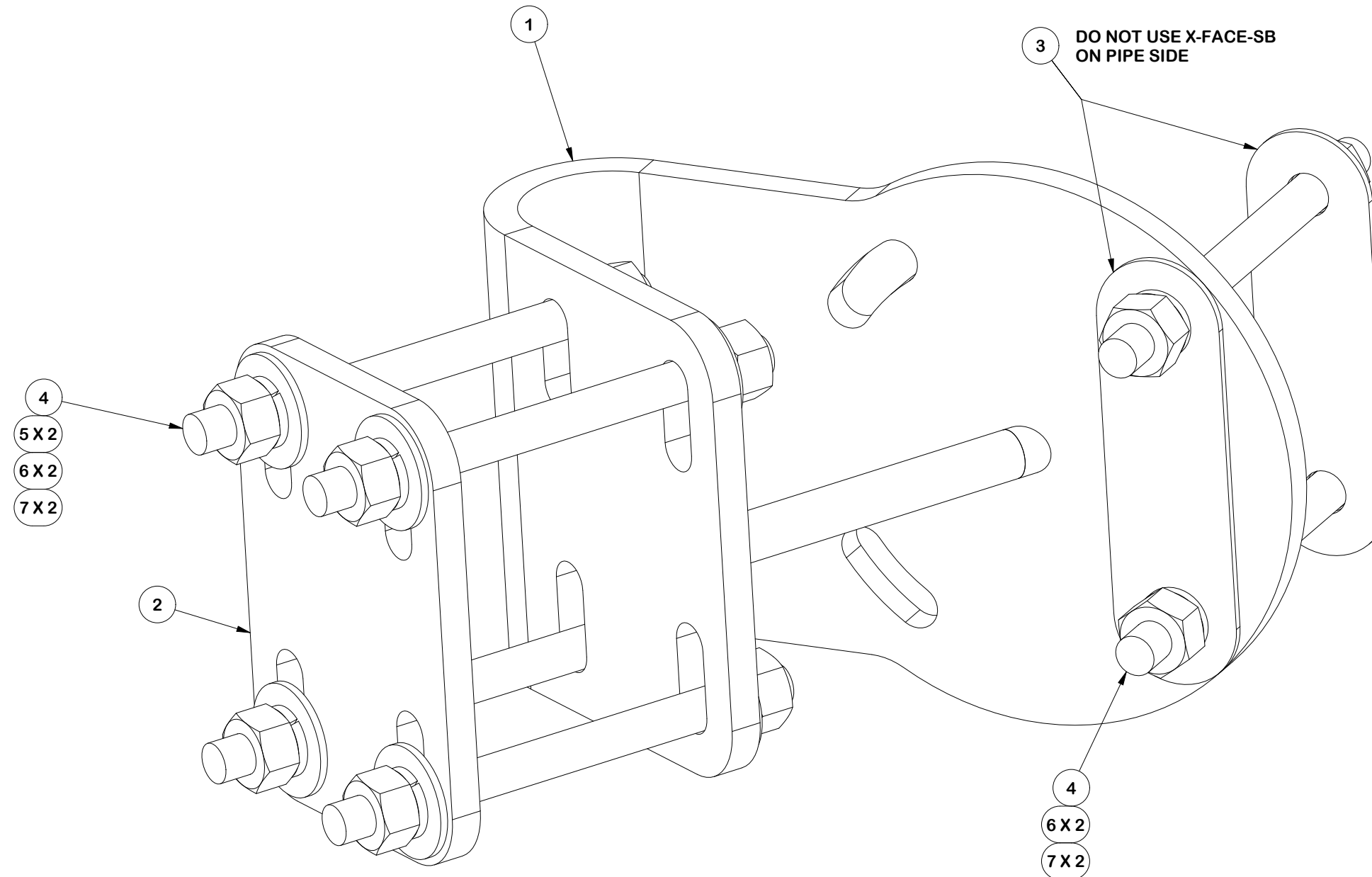

FINISH:  
HOT DIP GALVANIZED.

### TOLERANCE NOTES

TOLERANCES ON DIMENSIONS, UNLESS OTHERWISE NOTED ARE:  
 SAWED, SHEARED AND GAS CUT EDGES ( $\pm 0.030"$ )  
 DRILLED AND GAS CUT HOLES ( $\pm 0.030"$ ) - NO CONING OF HOLES  
 LASER CUT EDGES AND HOLES ( $\pm 0.010"$ ) - NO CONING OF HOLES  
 BENDS AND ANGLES ARE  $\pm 1/2$  DEGREE  
 ALL OTHER MACHINING ( $\pm 0.030"$ )  
 ALL OTHER ASSEMBLY ( $\pm 0.060"$ )

PATENT INFORMATION: WWW.SITEPRO1.COM/PATENTS

PROPRIETARY NOTE:  
 THE DATA AND TECHNIQUES CONTAINED IN THIS DRAWING ARE PROPRIETARY INFORMATION OF VALMONT INDUSTRIES AND CONSIDERED A TRADE SECRET. ANY USE OR DISCLOSURE WITHOUT THE CONSENT OF VALMONT INDUSTRIES IS STRICTLY PROHIBITED.

DESCRIPTION  
**SINGLE-SECTOR MICROWAVE KIT  
 W/ 2-7/8" DIA. X 132" HORIZONTALS  
 AND PIPE MOUNT**

CPD NO. <b>SP1</b>	DRAWN BY <b>SDR 2/18/2026</b>	ENG. APPROVAL <b>JET 3/2/2026</b>
CLASS <b>87</b>	SUB <b>02</b>	DRAWING USAGE <b>CUSTOMER</b>
CHECKED BY <b>CSL 3/2/2026</b>		



A valmont COMPANY

Engineering  
 Support Team:  
 sp1engineering@valmont.com

PART NO. <b>FACE-CCHALF</b>
DWG. NO. <b>FMW10-30</b>

PARTS LIST						
ITEM	QTY	PART NO.	PART DESCRIPTION	LENGTH	UNIT WT.	NET WT.
1	1	X-FACE-BP	BENT PLATE FOR X-HDCAMTBW	13 in	18.08	18.08
2	4	G58R-14	5/8" x 14" THREADED ROD (HDG.)		1.22	4.88
3	4	G58R-8	5/8" x 8" THREADED ROD (HDG.)		0.70	2.79
4	8	G58LW	5/8" HDG LOCKWASHER		0.03	0.21
5	8	G58NUT	5/8" HDG HEAVY 2H HEX NUT		0.13	1.04
					TOTAL WT. #	26.99

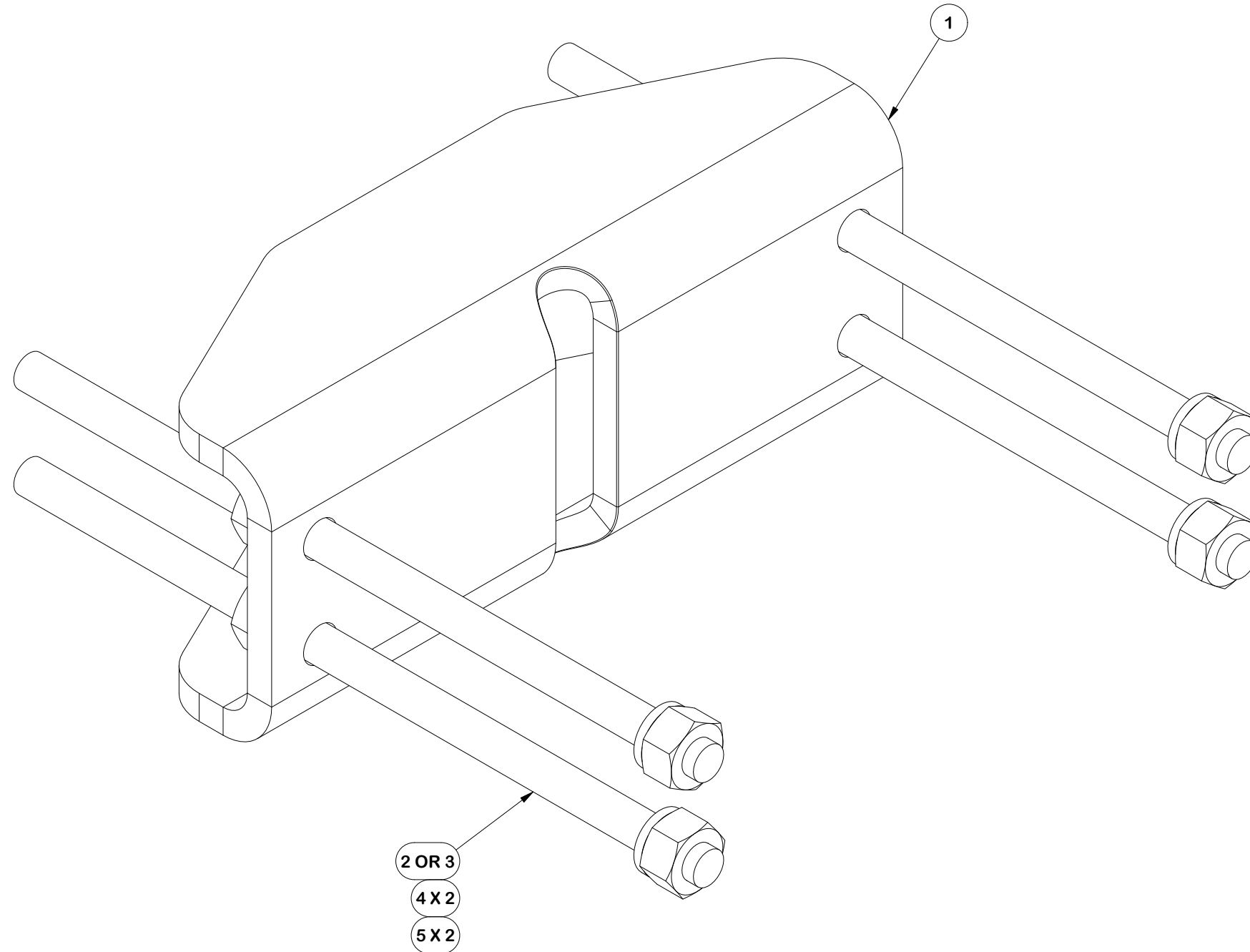

FINISH:  
HOT DIP GALVANIZED.

**TOLERANCE NOTES**

TOLERANCES ON DIMENSIONS, UNLESS OTHERWISE NOTED ARE:  
 SAWED, SHEARED AND GAS CUT EDGES ( $\pm 0.030"$ )  
 DRILLED AND GAS CUT HOLES ( $\pm 0.030"$ ) - NO CONING OF HOLES  
 LASER CUT EDGES AND HOLES ( $\pm 0.010"$ ) - NO CONING OF HOLES  
 BENDS AND ANGLES ARE  $\pm 1/2$  DEGREE  
 ALL OTHER MACHINING ( $\pm 0.030"$ )  
 ALL OTHER ASSEMBLY ( $\pm 0.060"$ )

PATENT INFORMATION: WWW.SITEPRO1.COM/PATENTS

PROPRIETARY NOTE:  
 THE DATA AND TECHNIQUES CONTAINED IN THIS DRAWING ARE PROPRIETARY INFORMATION OF VALMONT INDUSTRIES AND CONSIDERED A TRADE SECRET. ANY USE OR DISCLOSURE WITHOUT THE CONSENT OF VALMONT INDUSTRIES IS STRICTLY PROHIBITED.

DESCRIPTION  
**SINGLE-SECTOR MICROWAVE KIT  
 W/ 2-7/8" DIA. X 132" HORIZONTALS  
 AND PIPE MOUNT**



Engineering  
 Support Team:  
 sp1engineering@valmont.com

A valmont COMPANY

CPD NO.	DRAWN BY	ENG. APPROVAL
SP1	SDR 2/18/2026	JET 3/2/2026
CLASS	DRAWING USAGE	CHECKED BY
87	CUSTOMER	CSL 3/2/2026

PART NO.	FACE-LC
DWG. NO.	FMW10-30

PARTS LIST							LENGTH	UNIT WT.	NET WT.
ITEM	QTY	PART NO.	BOX NO.	PART DESCRIPTION					
1	1	P496		4-1/2" X 96" SCH. 40 GALVANIZED PIPE			96 in	91.60	91.60
2	2	FCX45-U	P-FCX45-U	HEAVY-DUTY UNIVERSAL CROSSOVER KIT				27.08	54.17
							TOTAL WT. #		145.77

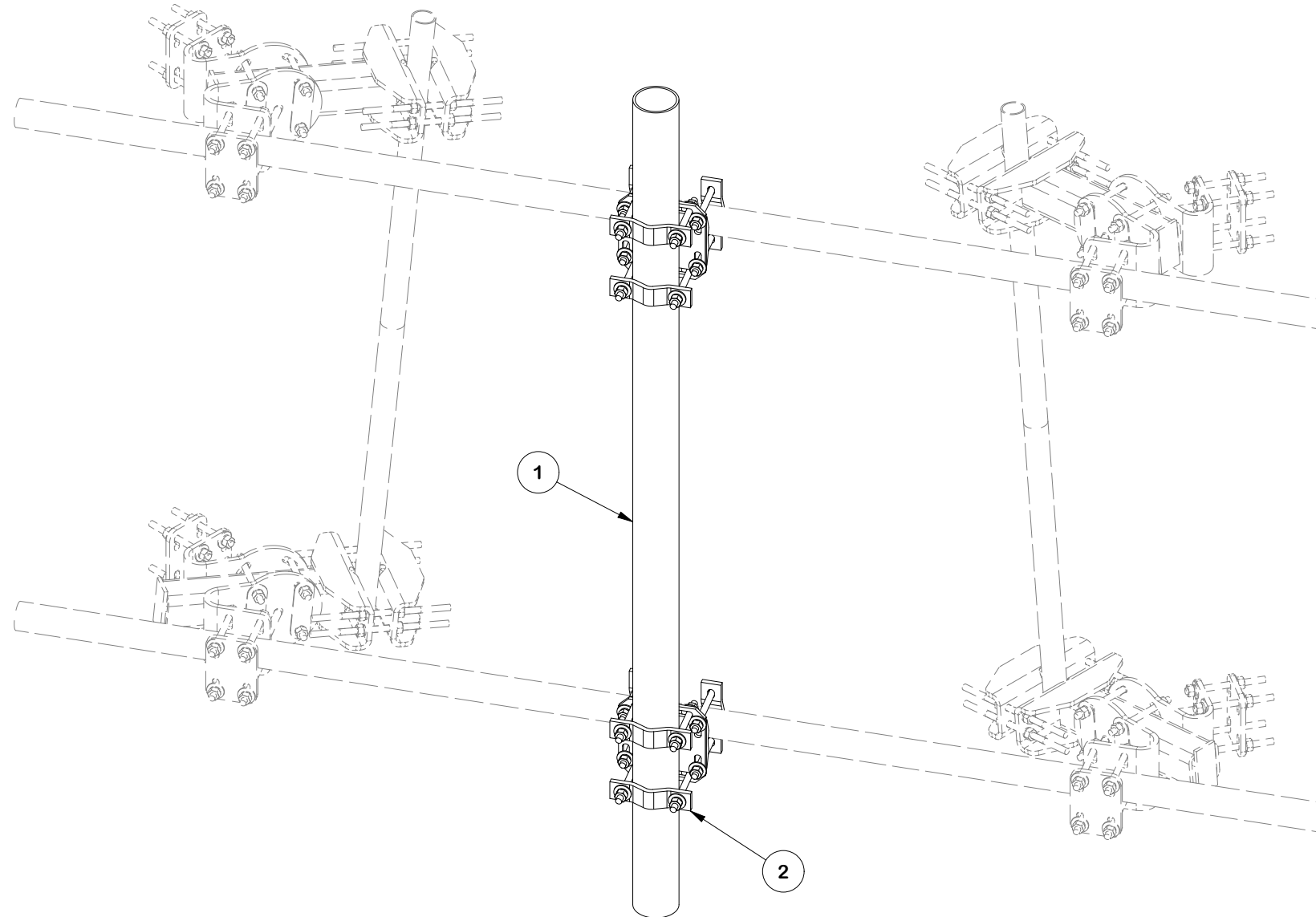

FINISH:  
HOT DIP GALVANIZED.

**TOLERANCE NOTES**

TOLERANCES ON DIMENSIONS, UNLESS OTHERWISE NOTED ARE:  
 SAWED, SHEARED AND GAS CUT EDGES ( $\pm 0.030"$ )  
 DRILLED AND GAS CUT HOLES ( $\pm 0.030"$ ) - NO CONING OF HOLES  
 LASER CUT EDGES AND HOLES ( $\pm 0.010"$ ) - NO CONING OF HOLES  
 BENDS AND ANGLES ARE  $\pm 1/2$  DEGREE  
 ALL OTHER MACHINING ( $\pm 0.030"$ )  
 ALL OTHER ASSEMBLY ( $\pm 0.060"$ )

PATENT INFORMATION: WWW.SITEPRO1.COM/PATENTS

PROPRIETARY NOTE:  
 THE DATA AND TECHNIQUES CONTAINED IN THIS DRAWING ARE PROPRIETARY INFORMATION OF VALMONT INDUSTRIES AND CONSIDERED A TRADE SECRET. ANY USE OR DISCLOSURE WITHOUT THE CONSENT OF VALMONT INDUSTRIES IS STRICTLY PROHIBITED.

DESCRIPTION  
**SINGLE-SECTOR MICROWAVE KIT  
 W/ 2-7/8" DIA. X 132" HORIZONTALS  
 AND PIPE MOUNT**

CPD NO.	DRAWN BY	ENG. APPROVAL
SP1	SDR 2/18/2026	JET 3/2/2026
CLASS	DRAWING USAGE	CHECKED BY
87	CUSTOMER	CSL 3/2/2026



Engineering  
 Support Team:  
 sp1engineering@valmont.com

A valmont COMPANY

PART NO. **FACE-PM496**

DWG. NO. **FMW10-30**

PARTS LIST						
ITEM	QTY	PART NO.	PART DESCRIPTION	LENGTH	UNIT WT.	NET WT.
1	1	X-SCX4-FR	4-1/2" FORTRESS CROSSOVER PLATE		8.10	8.10
2	4	DCP	1/2" THICK, 5-3/4" CNTR TO CENTER CLAMP HALF	8 1/8 in	2.36	9.45
3	8	G5807	5/8" x 7" HDG HEX BOLT GR5 FULL THREAD	7 in	0.70	5.64
4	16	G58FW	5/8" HDG USS FLATWASHER	1/8 in	0.07	1.13
5	8	G58LW	5/8" HDG LOCKWASHER		0.03	0.21
6	8	G58NUT	5/8" HDG HEAVY 2H HEX NUT		0.13	1.04
					TOTAL WT. #	25.62

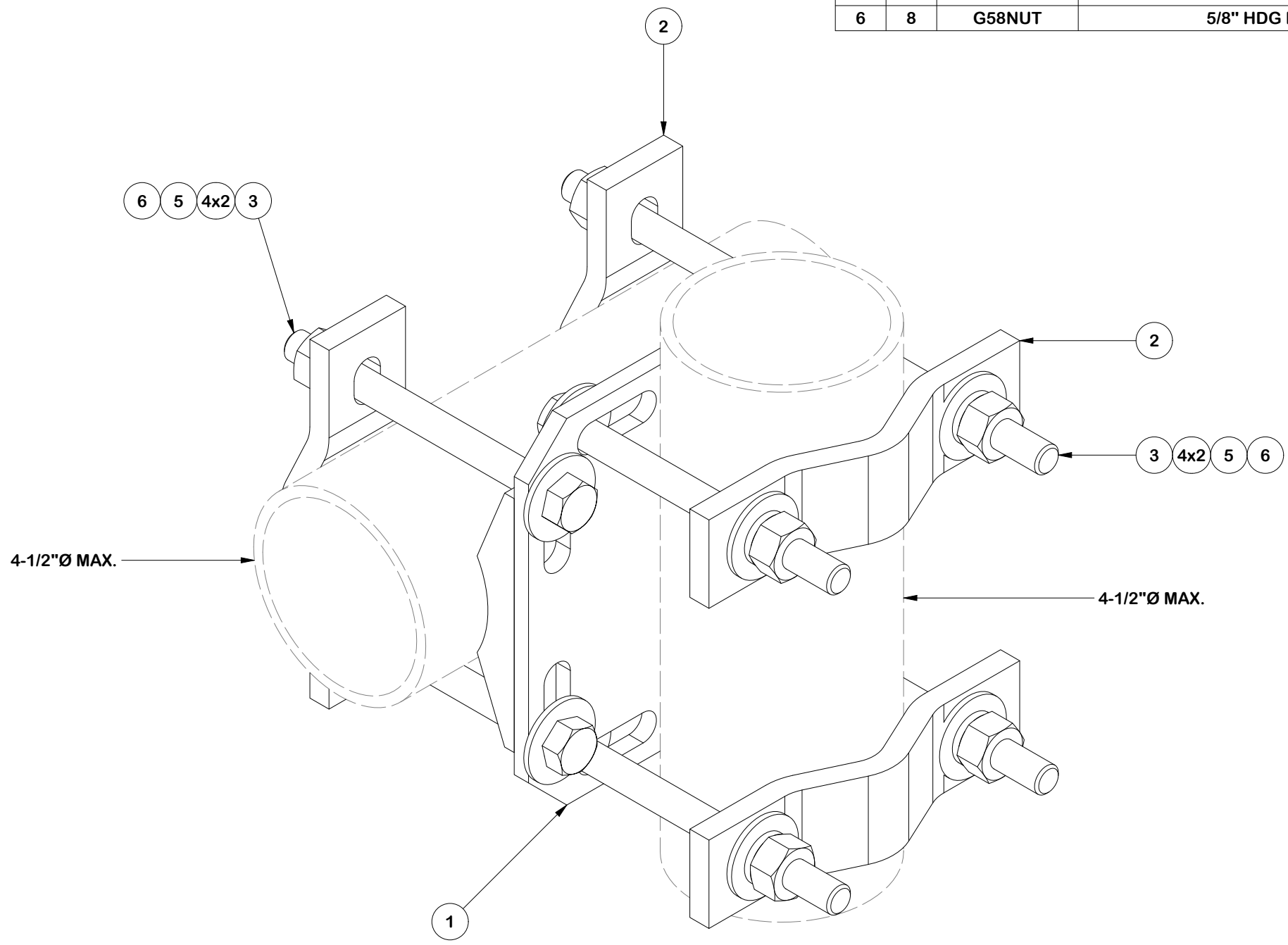

FINISH:  
HOT DIP GALVANIZED.

**TOLERANCE NOTES**

TOLERANCES ON DIMENSIONS, UNLESS OTHERWISE NOTED ARE:  
 SAWED, SHEARED AND GAS CUT EDGES ( $\pm 0.030"$ )  
 DRILLED AND GAS CUT HOLES ( $\pm 0.030"$ ) - NO CONING OF HOLES  
 LASER CUT EDGES AND HOLES ( $\pm 0.010"$ ) - NO CONING OF HOLES  
 BENDS AND ANGLES ARE  $\pm 1/2$  DEGREE  
 ALL OTHER MACHINING ( $\pm 0.030"$ )  
 ALL OTHER ASSEMBLY ( $\pm 0.060"$ )

PATENT INFORMATION: WWW.SITEPRO1.COM/PATENTS

PROPRIETARY NOTE:  
 THE DATA AND TECHNIQUES CONTAINED IN THIS DRAWING ARE PROPRIETARY INFORMATION OF VALMONT INDUSTRIES AND CONSIDERED A TRADE SECRET. ANY USE OR DISCLOSURE WITHOUT THE CONSENT OF VALMONT INDUSTRIES IS STRICTLY PROHIBITED.

DESCRIPTION  
**SINGLE-SECTOR MICROWAVE KIT  
 W/ 2-7/8" DIA. X 132" HORIZONTALS  
 AND PIPE MOUNT**

CPD NO. <b>SP1</b>	DRAWN BY <b>SDR 2/18/2026</b>	ENG. APPROVAL <b>JET 3/2/2026</b>
CLASS <b>87</b>	SUB <b>02</b>	DRAWING USAGE <b>CUSTOMER</b>
CHECKED BY <b>CSL 3/2/2026</b>		



Engineering Support Team:  
 sp1engineering@valmont.com

PART NO. <b>FCX45-U</b>
DWG. NO. <b>FMW10-30</b>